

A Versatile Starting Air or Control Relay Valve

TurboValve is a versatile, pilot-operated starting air or control relay valve used for the installation of TurboTwin Air Starters. TurboValve is a direct replacement for Sealco Models (10900, 11900, 14900, 110250) and Ingersol Rand (SRV125 and SRV150) relay valves. Its high flow capacity reduces pressure drop through the valve providing for a broad range of applications. A convenient auxiliary port allows you to tap pressure at the "IN" port for indication, control or pilot actuation. Operation of the TurboValve is simple. When either electricity is applied to the solenoid valve, or a control air is applied to the APP port, the main ports ("IN" and "OUT") are opened to allow full flow through the valve. When the start button or control air is released, the return spring closes the main port.

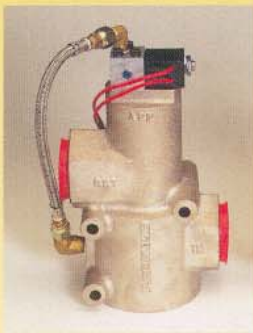

Electrically controlled
TURBOVALVE



T112-V *TURBOTWIN* with *TURBOVALVE*

TURBOVALVE

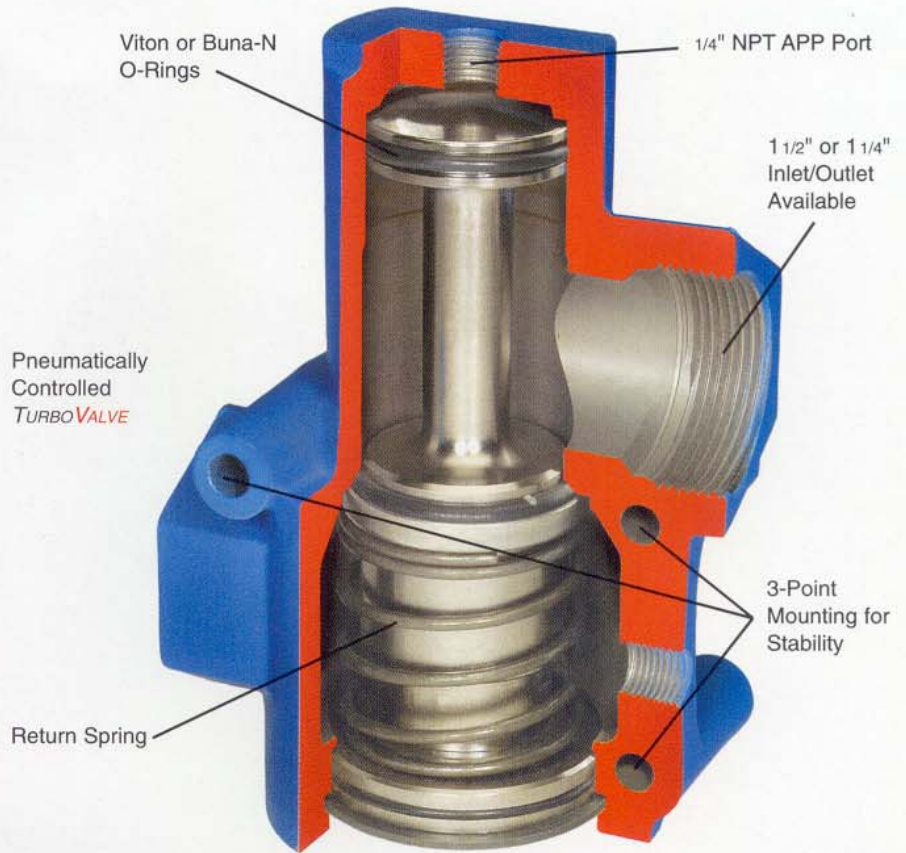

Features and Specifications

- Nickel-plated aluminum body
- Pressure Rating: 450 psig (31 Bar) rating for pneumatic versions
- 150 psig (10.3 Bar) for electro-pneumatic versions
- High flow capacity
CV factor: 42
- Replaceable O-rings (Viton or Buna-N)
- Compressed air only on electrically controlled version
- Simple, proven reliable relay valve design
- 1 1/4" or 1 1/2" NPT pipe sizes
- 3-point mounting for secure attachment to mounting bracket or frame
- -20° to 200° F (-29° to 93°C) operating temperature
- Lightweight ... only 2.9 lbs. (1.32 kg)
- Replaces Sealco (10900, 11900, 14900, 110250) and Ingersol Rand (SRV 125, SRV 150)
- Solenoid voltages (for electrically controlled versions): 12 VDC, 24 VDC, 110 VAC, 120 VAC



TECH DEVELOPMENT INC.

www.tdiairstarters.com

6800 Poe Avenue, P.O. Box 13557,

Dayton, Ohio 45413-0557

Tel: 937-898-9600 • Fax: 937-898-8431

Anything Less Than a *TURBOVALVE* is a Compromise

A part of Smiths Aerospace

AN03-663

Installation of a Complete Start System Has Never Been This Fast.

Bolt it on, connect the air line, attach the solenoid wires, and you're done. It's just that easy.

The TurboValve Plus is a completely integrated relay valve with solenoid that dramatically streamlines the installation process of TurboTwin air starters. Unlike traditional valves where component line-up and orientation issues are a real problem, the indexed mounting of TurboValve Plus assures a clean, consistent placement every time—without under-tightening and over-tightening of the valve. Simply bolt it on the starter, attach the solenoid wires, connect the air line and it's done!

A typical dual starting system with TurboValve can eliminate as many as 50 individual components! Add to that the elimination of product sourcing, procurement, inventory, staging, assembly labor, and TurboValve Plus is truly the economical solution. It allows you to spend less time plumbing and more time getting engines out the door.

TurboValve Plus can be used as a starting air valve or a relay control valve. Its indexable bolted joint mounting is solid, eliminating vibrations and providing added protection against thread-wear or having components shake loose due to vibration. It's a ready-to-go component that improves the productivity of your operation and the reliability of your start system.

TURBOVALVE PLUS

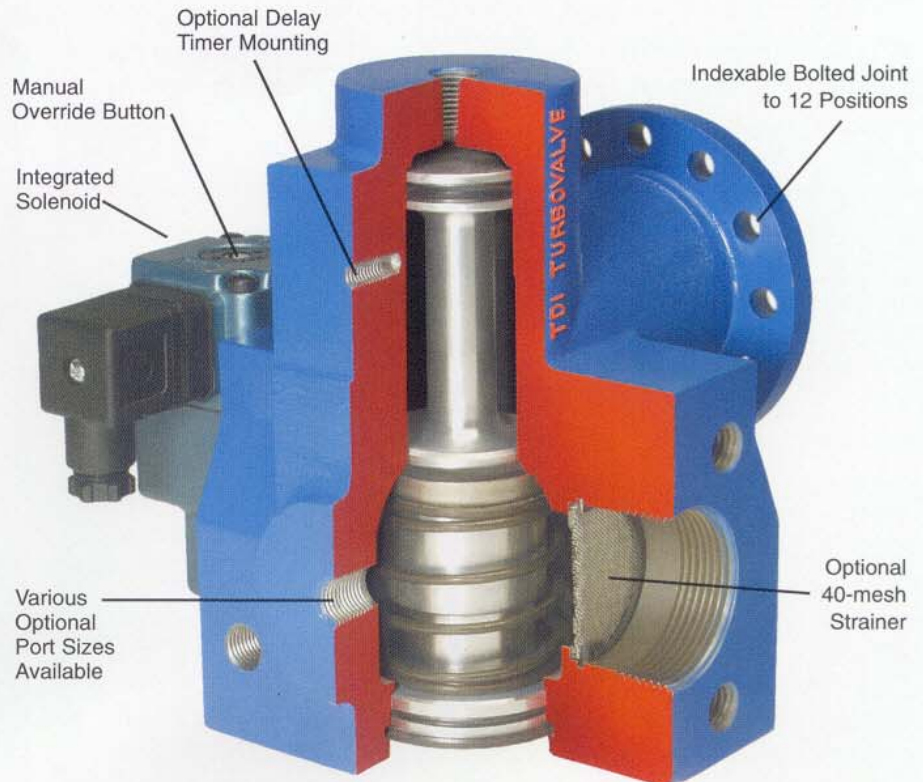

Features and Specifications

- Nickel-plated aluminum body
- Pressure Rating: 450 psig (31 Bar) rating for pneumatic versions
- 150 psig (10.3 Bar) for electro-pneumatic versions
 - High flow capacity CV factor: 42
 - Replaceable O-rings (Viton or Buna-N)
 - Compressed air only on electrically controlled version
 - 1 1/4" or 1 1/2" NPT and/or J518 code 61 size inlet
- Flanged outlet (to starter) for secure, consistent positioning
- Eliminates the need for numerous separate starting system components
- -20° to 200°F (-29° to 93°C) operating temperature
- Lightweight ... only 8.5 lbs. (3.86 kg)
- Eliminates many hours of installation labor
- Solenoid voltages available (for electrically controlled versions): 12 VDC, 24 VDC, 110 VAC, 120 VAC



T50-P with
TURBOVALVE PLUS



TECH DEVELOPMENT INC.

www.tdiairstarters.com

6800 Poe Avenue, P.O. Box 13557,
Dayton, Ohio 45413-0557

Tel: 937-898-9600 • Fax: 937-898-8431

Anything Less Than a **TURBOVALVE** is a Compromise

A part of Smiths Aerospace

AN03-663