

SPM-A Synchronizer

APPLICATIONS

Woodward's Speed and Phase Matching (SPM-A) Synchronizer provides automatic frequency and phase matching when used with 2301, 2301A, and Electrically Powered Governor (EPG) electric load sharing control systems.

DESCRIPTION

The SPM-A Synchronizer automatically generates a signal to bias the speed of the prime mover of an off-line generator so its frequency and phase match those of the bus. Tight control action is obtained by feeding the synchronizer's speed bias signals directly into the electronic control's speed loop error amplifier rather than through a motor-operated speed-setting potentiometer. The synchronizer automatically issues a signal to close the circuit breaker connecting the off-line unit to the bus when phase and frequency are matched within limits.

Four operating modes (Run, Check, Permissive, and Off) facilitate system testing and installation checkout without electrically disconnecting the synchronizer from the control system. These four modes are selected by an external switch (customer supplied) connected to the SPM-A Synchronizer.

The **RUN** mode allows synchronization and automatic breaker closure.

The **CHECK** mode allows testing correct synchronizing operation, but without circuit breaker closure.

The **PERMISSIVE** mode allows checking for acceptable synchronization, but does not trim speed or adjust voltage. If synchronization is correct, the breaker is allowed to close.

In the **OFF** mode, the synchronizer is out of operation.

The synchronizers are used in generator installations. Dynamics are adjustable. Only one model is required for fast or slow dynamics. The synchronizer is compatible with small or large diesels, gasoline or gas engines, and steam or gas turbines. Fast dynamics are designed to match the fast dynamics of small- to medium size diesel engines. Slow dynamics are designed to match the slower dynamics of large diesel engines and turbo machinery and gas or gasoline engines.

There are four distinct functions in the SPM-A Synchronizer: the speed bias circuit, the enable circuit, the breaker closure circuit, and the voltage comparator circuit. See the Synchronizer Block Diagram.

Speed Bias Circuit

By using the phase lock technique to compare bus and generator voltages, the speed bias circuit output causes the off line generator set, through the bias circuit to the electronic control, to alter speed to match the bus phase angle. A lockout circuit disconnects the speed bias output when the close breaker command ceases. The synchronizer output then remains disconnected until it is automatically reset. This reset will take place if the speed of the oncoming unit drifts outside the permissive synchronizing window.

Enable Circuit

The enable circuit provides a secondary relative phase angle check and a coarse bus and generator voltage comparison. When conditions are acceptable, the enable circuit permits the breaker close

- UL and cUL Listed
- CSA Certified
- EU EMC Directive Compliant
- Automatic Synchronization of Generators
- Adjustable Dynamics
- Frequency, Phase, and Optional Voltage Matching
- Selectable Match Up Time
- Automatic Breaker Closure
- Selectable Output Impedance

circuit to issue a close breaker command. The enable circuit increases system reliability by preventing single-point failures from causing the close breaker command to be erroneously issued.

Breaker Close Circuit

The breaker close output, unless inhibited by the enable circuit, issues the command to close the main breaker if conditions are acceptable. If the relative phase angle between the bus and the generator voltages is zero and stays zero while the main breaker is closing, perfect synchronization and paralleling result. It is not necessary that the phase angle always be zero, just that the phase angle be less than the greatest allowable value, which is +10 degrees (within the "window") and has been within the window for the window dwell time.

The synchronizer's phase match window dwell time may be chosen (by an internal selection switch for 1/8, 1/4, 1/2, or 1 second) to ensure that the phase angle is less than the greatest allowable phase difference when the breaker contacts engage. The close breaker command consists of the breaker close relay changing state for about one second. Refer to the Selection and Adjustment section for standards.

Voltage Comparator Circuit

In the voltage matching model, the voltage comparator circuit of the synchronizer compares bus and off-line generator voltages. When voltages are equal, there is no comparator circuit output. If a difference of input voltage exists, an increase or decrease relay signal is sent to the generator's voltage regulator. Where a difference in voltage exists, the breaker closure circuit and the speed/phase output are inhibited.

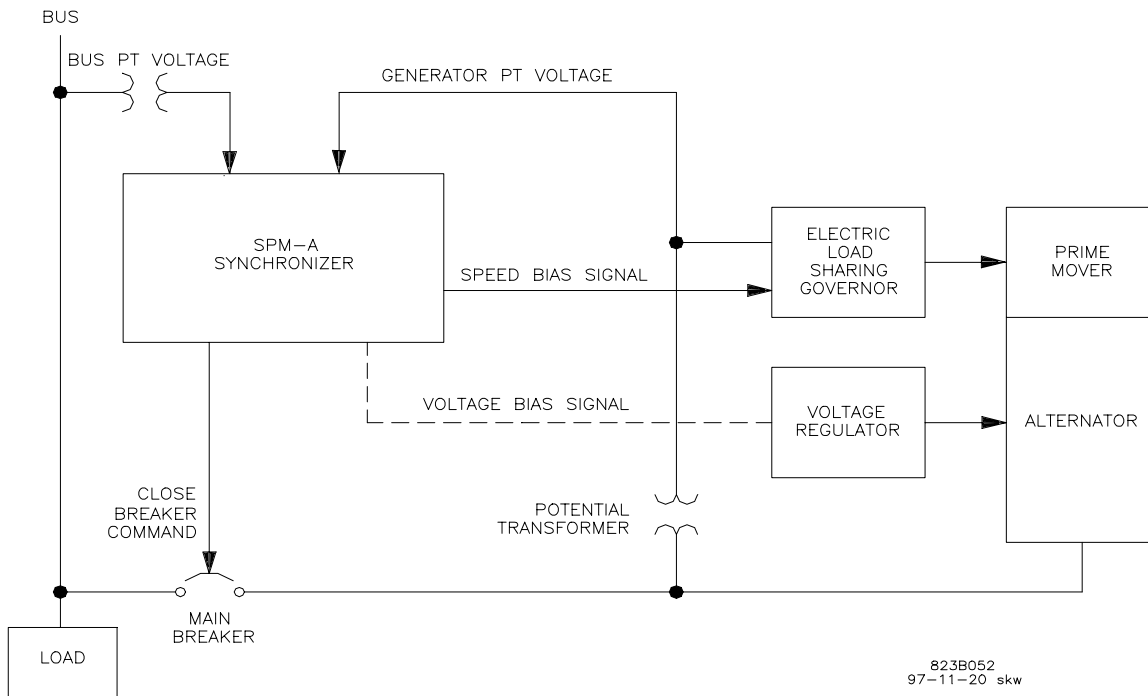

Synchronizer Functional Diagram

SPECIFICATIONS

UL RECOGNIZED (N) E97763 CSA CERTIFIED LR 46653 EMC DIRECTIVE COMPLIANT PERFORMANCE ON UNITS BEARING THE APPROPRIATE AGENCY LOGO

Typical Synchronizing TimeUnder 5.5 seconds from a dead start. (Measured on a diesel engine generator set with 55%/second acceleration rate and governor at optimum settings.)
Normal Speed Bias Range.....The speed bias output can effect a ± 1.5 Hz frequency change at both 50 and 60 Hz generator frequencies.

INPUTS

Voltage (Bus and Generator) 115 or 230 Vac rms 50/60 Hz
Voltage Tolerance+1.0 %.
Power Consumption.....5 watts maximum, from generator input.

OUTPUTS

Electronic Control Compatibility

- High impedance output for 2301 electronic load sharing control systems
- Low impedance output for 2301A, EPG, and 2500 load sharing control systems and EGA or EGM with external resistor
- EPG output for Electrically Powered Governor (EPG) without load sharing

Breaker Close RelayNormally open contacts provided
Breaker Close Relay Contact Ratings
Resistive Loads

- 10 amps at 28 Vdc
- 3 amps at 115 Vac, 50/60 Hz
- 1.5 amps at 230 Vac, 50/60 Hz

Inductive Loads

- 6 amps at 28 Vdc
- 2 amps at 115 Vac, 50/60 Hz
- 1 amp at 230 Vac, 50/60 Hz

Breaker Close Command DurationApproximately 1 second
Enable IndicatorLighted when the enable circuit is satisfied

SELECTIONS AND ADJUSTMENTS

Operating Modes.....Run, Check, Permissive, and Off modes. External wiring provides remote mode switching by customer supplied switch.
Synchronizer ResetThe synchronizer is reset automatically.
Phase Match Window ± 10 degrees is standard
Match Up Time.....1/8, 1/4, 1/2, or 1 second are selectable with an internal switch. (Set for 1/2 second at factory.)
Voltage Matching Range1% or 5% are standard (other values available at special request).
Phase OffsetCompensates for any phase shift between the power source and the synchronizer circuit within a 15 degree range.
Voltage OffsetCompensates for any voltage shift between the power source and the synchronizer circuit within 29% of the input voltage.
Stability and GainMatches the dynamics of the synchronizer to the dynamics of the electronic control being used.

PHYSICAL INSTALLATION

Location.....Mount with switch gear
Weight.....2.2 kg (5 pounds)
Ambient Temperature Range.....-54 to +65 °C (-65 to +150 °F)

Woodward/
 Industrial Controls
 PO Box 1519
 Fort Collins CO, USA
 80522-1519
 1000 East Drake Road
 Fort Collins CO 80525
 Ph: (1)(970) 482-5811
 Fax: (1)(970) 498-3058

Distributors & Service
 Woodward has an international network of distributors and service facilities. For your nearest representative call (1)(800) 835-5182 or see the Worldwide Directory on our web site.

Corporate Headquarters
 Rockford IL, USA
 Ph: (1)(815) 877-7441

www.woodward.com

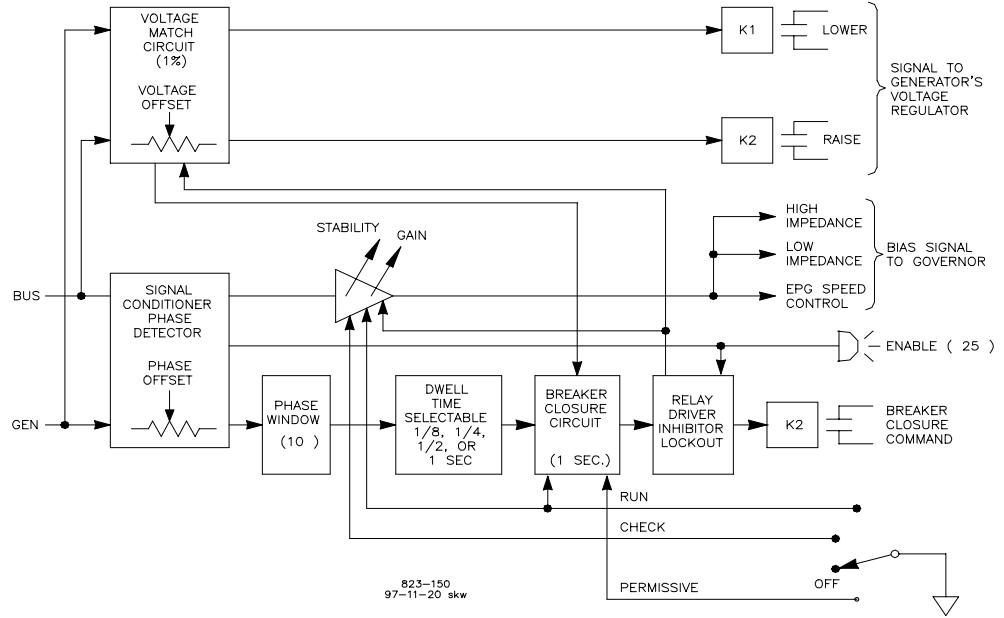

Synchronizer Block Diagram

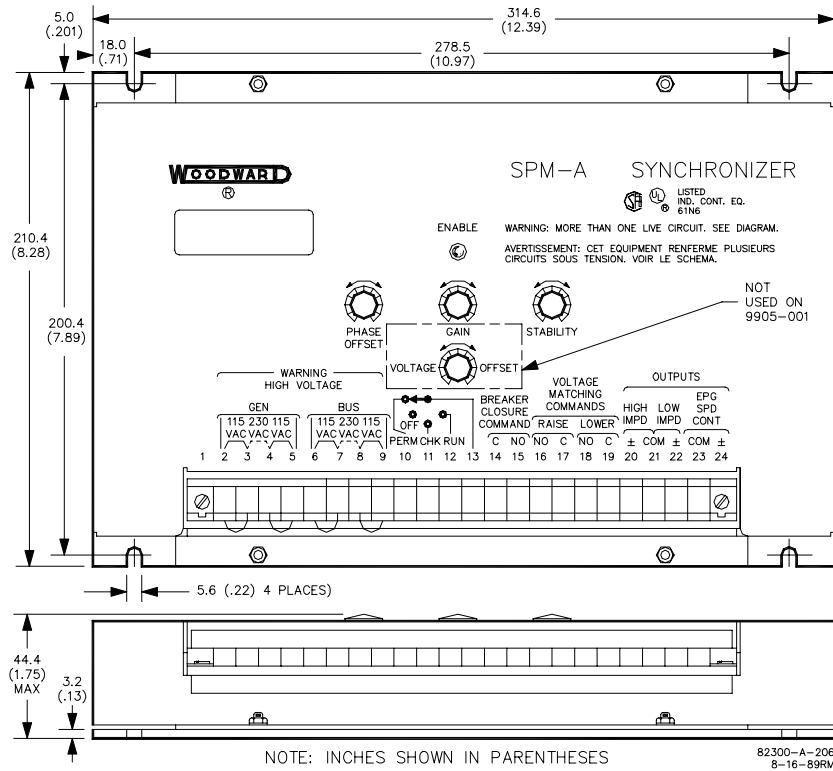

SPM-A Outline Drawing

This document is distributed for informational purposes only. It is not to be construed as creating or becoming part of any Woodward Governor Company contractual or warranty obligation unless expressly stated in a written sales contract.

© Woodward Governor Company, 1986
 All Rights Reserved

01/01/F

For more information contact: