

# Peak<sup>®</sup> 150

## Digital Control for Steam Turbines

The Peak<sup>®</sup> 150 steam turbine control is a low-cost, compact, digital control for single-valve or single-valve rack steam turbines. It provides convenient operator control and speed display from the front panel. It is housed in a watertight, and dust-tight, enclosure. A corrosion-resistant enclosure designed to meet NEMA 4X requirements is also available.

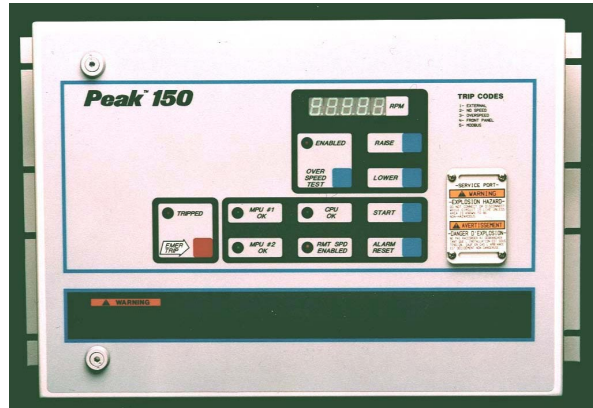

### APPLICATIONS

The Peak 150 digital control is designed to control a steam turbine driving a mechanical load. It provides tight control of speed (NEMA D) and includes an input for a 4–20 mA remote speed control signal, which can be used for a process-generated input to control the speed setting. Other features include dual speed control dynamics and overspeed trip test capabilities.

### OPERATION

The operation of the control is simple. To start the turbine, the steam-supply valve must be opened (manually or by other means). When the turbine comes up to the user-determined idle speed, the Peak 150 system takes control of the turbine—the steam-supply valve can then be opened fully. The Peak 150 control includes circuitry for detecting the loss of either MPU signal—this circuitry is automatically overridden for starting.

The turbine can be accelerated from idle speed to minimum governor speed either automatically (by using the remote Idle/Min Gov contacts or by using the front panel start), or manually (by using the front panel or remote Raise or Lower commands).

### SETPOINT ADJUSTMENTS

#### Manual Mode

Turbine speed is adjusted solely by the front panel keys and the remote Raise and Lower discrete inputs. The Remote Speed setting analog input is ignored in this mode.

#### Remote Speed Set Mode

Turbine speed is determined by the Remote Speed Setting analog input. When the Remote Speed Setting Enable contact is closed and the turbine is at or above minimum governor speed, turbine speed will ramp from Min Gov Speed to the remote value at a user-defined rate. Once the speed setpoint output matches the setting of the Remote Speed Setting signal, the speed will change at a new user-defined rate for process control. If the Remote Speed Setting signal is disabled for any reason, the speed setpoint will remain at the last speed and the setpoint adjustment operates as it does in Manual Mode.

#### Combination Mode

This mode is similar to the Analog Remote Speed Set Mode, except that the speed demand generated by the discrete (front-panel and remote Raise and Lower contact inputs) and the analog Remote Speed Setting signal are compared for the highest value. This highest value is passed on as the commanded speed. If the Remote Speed Setting signal is disabled for any reason, control of the speed setpoint operates as it does in Manual Mode.

- Low-cost digital steam turbine control
- 16-bit, 12 MHz microprocessor
- Rugged NEMA 4 or NEMA-4X enclosure
- Front-mounted operator keypad and rpm/status indicators
- Easy setup and tuning using plug-in, hand-held terminal
- Modbus<sup>®</sup> communications capability
- Part of our Total Turbine Control System

## PROGRAMMING UNIT

A small hand-held programmer (see illustration) connects to the Peak 150 to permit system configuration and tuning. System constants cannot be changed without this unit, so unauthorized changes are easily prevented by limiting access to the programmer.

## CRITICAL SPEED AVOIDANCE

To protect the turbine and skid from excessive vibration, a critical speed band can be defined by the user. While within this band, turbine speed will change at a fast rate (user-defined) and cannot be stopped within the band.

## COMMUNICATIONS

Serial communication using the Modbus<sup>®</sup> protocol is an option on the Peak 150. The transmission mode can be configured to be either RTU or ASCII mode. RS-232, RS-422, and RS-485 will all be supported through wiring to the proper terminals. Modbus, when purchased, permits communication with Programmable Logic Controllers or Distributive Control Systems. Speed, speed setpoint, alarm and shutdown conditions, and other pertinent control information will be reported on request from a master unit.

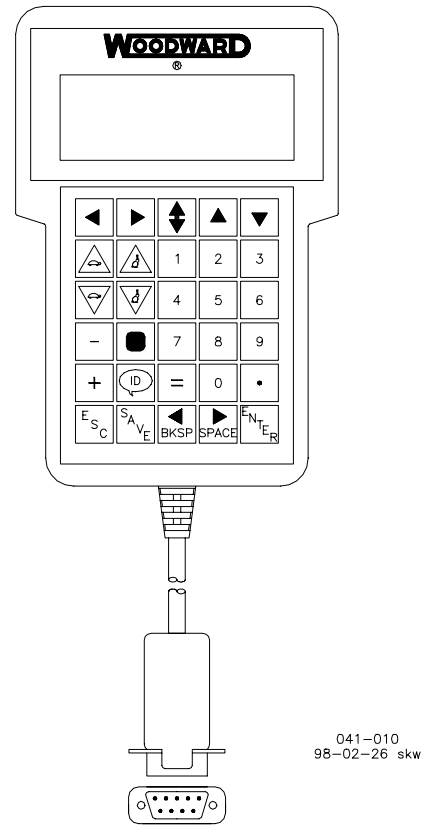

Hand Held Programmer

## SPECIFICATIONS

### Inputs

Magnetic Pickup Inputs (2)

Two identical inputs, high-signal-selected  
Minimum input voltage 1 Vrms, minimum frequency 200 Hz,  
maximum frequency 15 kHz

Analog Input (1)

Remote Speed Setting signal  
(4–20 mA or 1–5 Vdc, internal jumper selectable)

Discrete Inputs (8)

Remote (isolated, 5–28 Vdc)

Options

Raise speed  
Lower speed  
Emergency stop  
Alarm reset  
Remote speed set enable  
Start  
Idle/minimum governor  
Select high dynamics or overspeed test

### Outputs

Analog Outputs (2)

Actual speed output (scalable, 4–20/0–1 mA)  
Configurable readout (scalable, 4–20/0–1 mA)

Options

Actual speed  
Speed setpoint  
Actuator output  
Remote speed setpoint  
Valve ramp value

Actuator Output (1)

4–20 or 0–200 mA (internal jumper selectable)

Relay Outputs (4)

Internal jumpers provide choice of normally-open or normally-closed contacts

## SPECIFICATIONS (continued)

---

Contact ratings are	2 A resistive @ 28 Vdc 0.3 A resistive @ 115 Vac Shutdown (de-energizes or energizes for shutdown) Alarm (de-energizes for alarm) Configurable Relay #1 Configurable Relay #2
Options	Alarm Trip output Shutdown Remote control Speed control MPU failure Overspeed trip Overspeed test Remote signal OK Speed switch #1 Speed switch #2 Hand valve #1 Hand valve #2

### Operator Control Panel

Keypad Switches (6)

Options

Raise speed  
Lower speed  
Emergency trip  
Start  
Overspeed test  
Alarm reset

LED Indicators (6)

Remote speed setting signal status  
Shutdown status  
MPU #1 status  
MPU #2 status  
CPU status  
Overspeed test status

Digital Display

Five-digit LED speed display

### Power

Input

Models are available with these input power requirements:  
24 Vdc  
90–150 Vdc or 88–132 Vac, 47–63 Hz  
38 W

Maximum power consumption, all models:

### Environmental Specifications

Operating Ambient Temperature

–25 to +65 °C (–13 to +149 °F)

Storage Ambient Temperature

–40 to +85 °C (–40 to +185 °F)

Humidity

Designed to meet US MIL-STD-810D, Method 507.2, Procedure II, induced, non-hazardous, cycle 5 (fifteen 24-hour cycles, varying 19–75% humidity, over 33–63 °C)

North American Regulatory Compliance

UL and cUL listed for Class 1, Division 2, Groups A, B, C, & D

### Dimensions

Width

483 mm (19 inches)

Height

310 mm (12.2 inches)

Depth

105 mm (4.1 inches)

Woodward  
 Industrial Controls  
 PO Box 1519  
 Fort Collins CO, USA  
 80522-1519  
 1000 East Drake Road  
 Fort Collins CO 80525  
 Ph: +1 (970) 482-5811  
 Fax: +1 (970) 498-3058

**Distributors & Service**  
 Woodward has an international network of distributors and service facilities. For your nearest representative, call the Fort Collins plant or see the Worldwide Directory on our website.

**Corporate Headquarters**  
 Rockford IL, USA  
 Ph: +1 (815) 877-7441

[www.woodward.com](http://www.woodward.com)

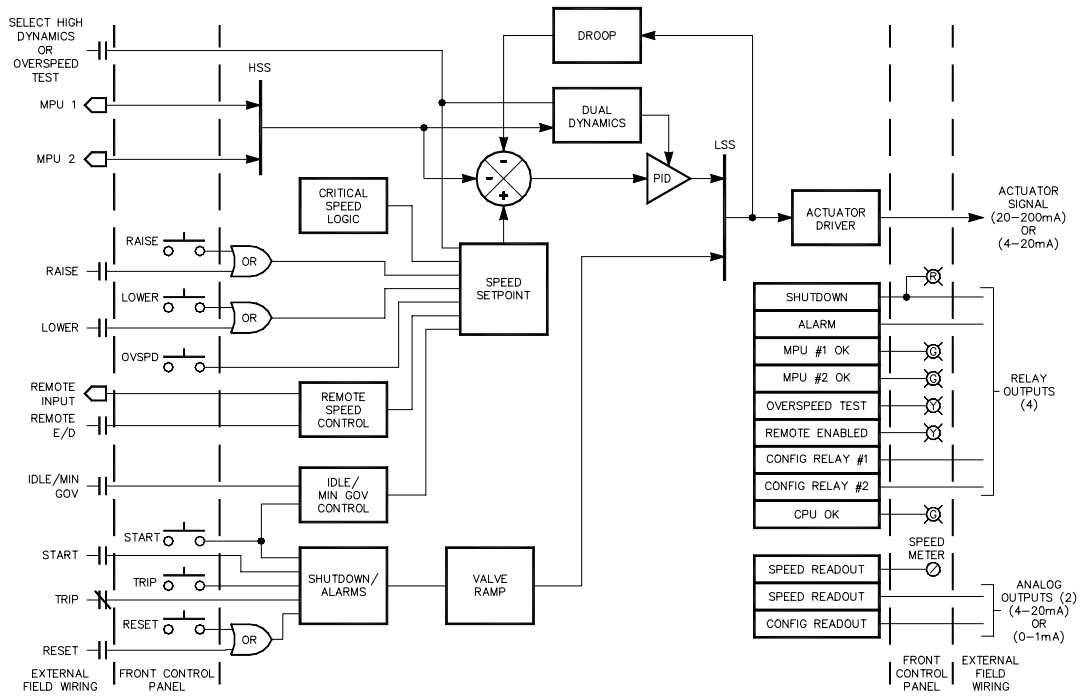

855-307  
 93-08-27 DAR

**Block Diagram**

This document is distributed for informational purposes only. It is not to be construed as creating or becoming part of any Woodward Governor Company contractual or warranty obligation unless expressly stated in a written sales contract.

© Woodward Governor Company, 1990  
 All Rights Reserved

For more information contact: