

Automatic Generator Loading Control (AGLC)

APPLICATIONS

Used to soft load in and out of a loadsharing loop: Loading is initiated by a generator circuit breaker auxiliary contact. Unloading is initiated by a momentary opening of an unload contact. When the circuit breaker closes, the load will be increased at three preset ramp rate until matched with other units. The AGLC then tracks the load on the set and, on the unload signal causes the set to unload at the ramp speed. When the unload trip level is reached, a relay activates in the AGLC which can be used to open the breaker for a smooth, bumpless power transfer.

Used to base load 1 to 15 generator sets joining a utility: The base-load reference switch is closed or jumpered and the control automatically causes the system to ramp to the preset base-load level after the breaker closes.

The base load is set with an internal potentiometer, or an external potentiometer. The base load setting can be used to increase or decrease load on the set or on the system. A limit prevents the base load from being set higher than the maximum desired load.

Used to unload a generator set before leaving the bus: The unload trip level is adjusted by a potentiometer on the AGLC, or by an external potentiometer. When the unload switch is momentarily opened the AGLC causes the set or system to ramp down to the previously set trip point where it stops unloading and activates a relay which can be used to open the breaker. The relay resets when the breaker opens.

The trip level can be matched to blower or pump loads on the machine before closing the bus. This use eliminates a shift of load and bump when separating from the rest of the system.



DESCRIPTION

The Automatic Generator Loading Control (AGLC) is for use with Woodward load sharing and speed control systems with either built-in or external load sensors. It is designed to provide soft loading or unloading of a generator set into or out of a loadsharing system at controlled rates. It can also soft load or unload a single unit, or up to 15 paralleled loadsharing units, into or out of parallel with a utility and then set a specific base load on the generating system.

The versatile control simplifies the logic and wiring required to perform these functions.

The electronic ramps are easily adjusted from 5 seconds to 5 minutes for 100 percent load change. (Actual load and unload times will depend on the capabilities of the engine.) The load and unload ramp rates are separately adjusted.

The AGLC tracks the load on the generator set at all times and starts the ramp at the load on the set, eliminating any bump and providing smooth transfer of power, whether loading or unloading.

- Bumpless Power Transfer
- Soft Loading and Unloading
- Electronic Ramps
- Separately Adjustable Raise and Lower Ramp Rates
- Ramps to Set Generator Load to Adjustable Base Load
- UL and cUL Certified

FEATURES

Breaker Open Contacts

When reaching the set trip level the AGLC will automatically de-energize a double-throw relay. The relay can be used to initiate separation of the generator set from the rest of the system. The relay will energize when the circuit-breaker auxiliary contacts open.

Adjustable Base Load

The load on a generator set is increased at the ramp rate to a base-load setting. The base-load level can be set using an internal potentiometer accessible through the cover or by an external potentiometer. When the base-load contact is opened, the unit will ramp back to load share.

When the AGLC is used to base load a number of engine-generator sets operating against an infinite bus, the system will return to isochronous load share when the utility auxiliary breaker contact opens. Only the unit load sharing lines are connected between the AGLC and the load sharing connections of the separate sets when controlling multiple units in base load with one AGLC.

A Bumpless Transfer of a Loaded Local Bus to a Utility

The base-load reference can be set to match the existing load by connecting a meter from terminals 7 to 12 and adjusting the base-load reference for zero volts. The adjustment can be used to obtain a zero power transfer at constant load using the AGLC to control load while paralleling a loaded local bus to a utility.

Variable Base Load

The base-load feature can be used to cut down on engine maintenance on a system where multiple engines are only lightly loaded. By periodically shifting one engine generator set to base load, then loading that engine to near capacity for a given time, the carbon buildup can be burned away. The unit will return to isochronous load share under ramp control when the cycle is completed and the base-load contact is opened.

Maximum Load Limit

A separate setting provides a high limit to the base-load setting. This provides protection against erroneous setting of the base load.

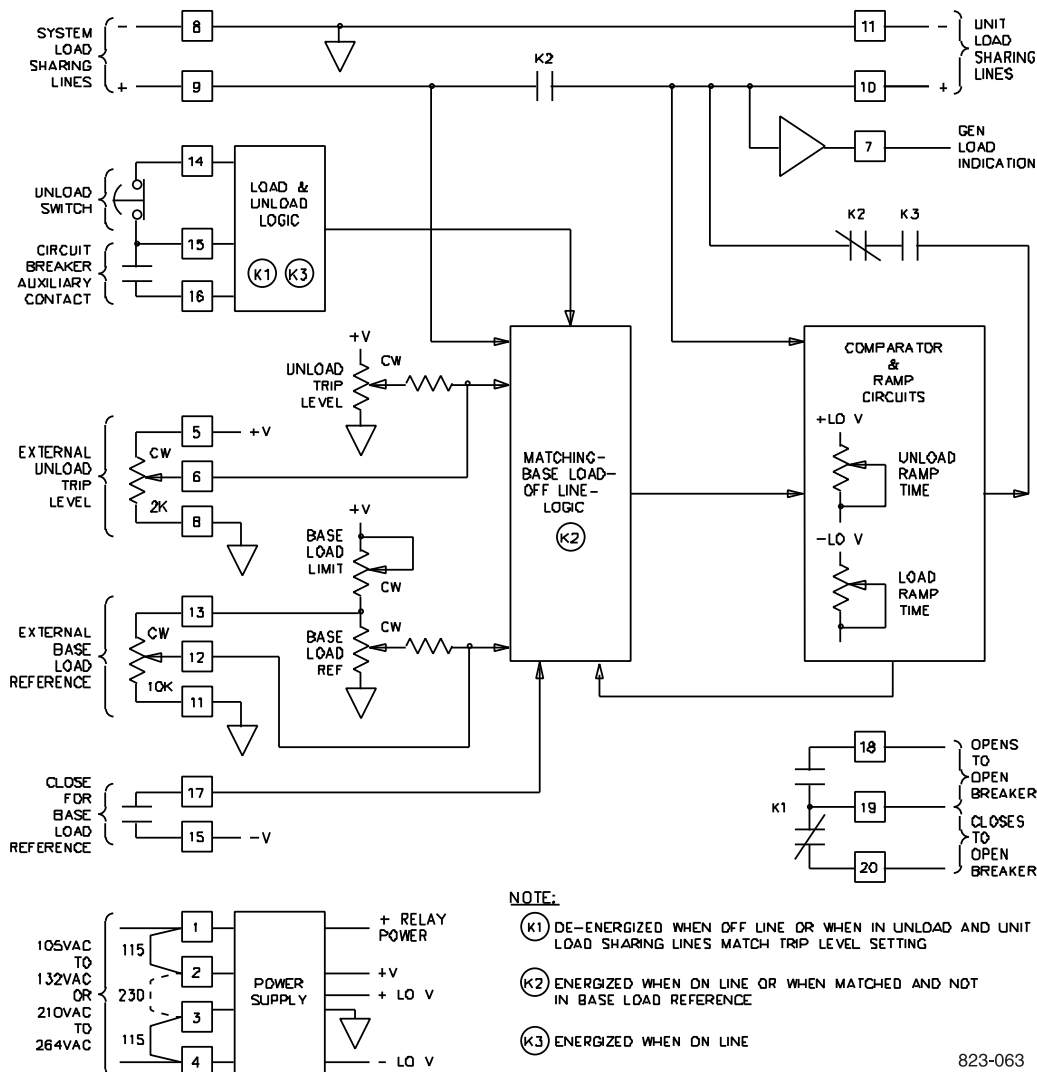

823-063

AUTOMATIC GENERATOR LOADING CONTROL BLOCK DRAWING

AUTOMATIC SIGNALS

Circuit Breaker auxiliary contacts are used to initiate the generator load ramp for either loadshare matching or for base load.

A relay de-energizes when the unload trip level is reached by the unload ramp. Double throw contacts are brought out for the customer's use.

BREAKER OPEN RELAY CONTACT RATING

	Resistive	Inductive	Motor	Lamp
28 Vdc	10 Amp	6.0	3.0	1.0
115 V, 400 Hz	5 Amp	2.5	3.0	0.8
115 V, 60 Hz	3 Amp	2.0	1.5	0.5

SELECTIONS

BASE LOAD

Closing switch contacts at the Close for Base Load Reference terminals while the auxiliary breaker contacts are

closed will cause load to be changed at the load-ramp rate to the baseload setting. The load will ramp up or down to the base-load position.

Where only base loading is desired, the baseload-reference terminals can be jumpered. Base loading is then initiated whenever the auxiliary breaker contacts are closed.

Base-load reference is set with an internal potentiometer, or a 10 K external potentiometer. External setting takes preference over the internal setting. Base-load limit is set with an internal potentiometer to prevent overload.

UNLOAD RAMP

Opening switch contacts at the Open to Unload terminals will cause the AGLC to ramp down at the selected ramp rate whether the switch is left open or if it is again closed. This switch must be closed to load the system.

The unload-trip level is set by an internal potentiometer or by a 2 K external potentiometer. External setting takes preference.

SPECIFICATIONS

Input Power88-132 Vac, 50 or 60 cycles, power consumption 2.5VA. 170-264 Vac, 50 or 60 cycles, power consumption 5 VA

Ramp Ratesadjustable between 20 and 0.33 percent of full load per second (5 seconds to 5 minutes). Adjustments use single-turn log-taper potentiometers giving fine adjustment at the faster rates and coarser adjustment at the slower rates. (Actual minimum load and unload times will depend on the capabilities of the engine.)

ENVIRONMENTAL SPECIFICATIONS

Operating Temperature-40 to +85 °C (-40 to +185 °F)

Storage Temperature-55 to +105 °C (-67 to +221 °F)

Maximum Humidity95 percent at 38 °C (100 °F)

Vibration4 Gs between 5 to 500 Hz

Shock60 Gs

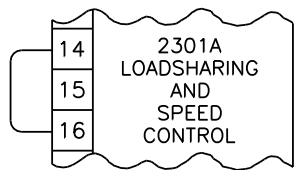

TERMINAL 14 AND 16 MUST BE JUMPERED WHEN AGLC IS CONNECTED

① CONNECTIONS SHOWN AT 8, 9, 10, AND 11 ARE FOR CONNECTION OF A SINGLE UNIT TO A SYSTEM. FOR CONTROL OF MULTIPLE UNITS CONNECTED TO A UTILITY CONNECT UNIT LOAD SHARING LINES 10 AND 11 TO THE SYSTEM LOAD SHARING LINES. (TERMINALS 8 AND 9 ARE LEFT OPEN.)

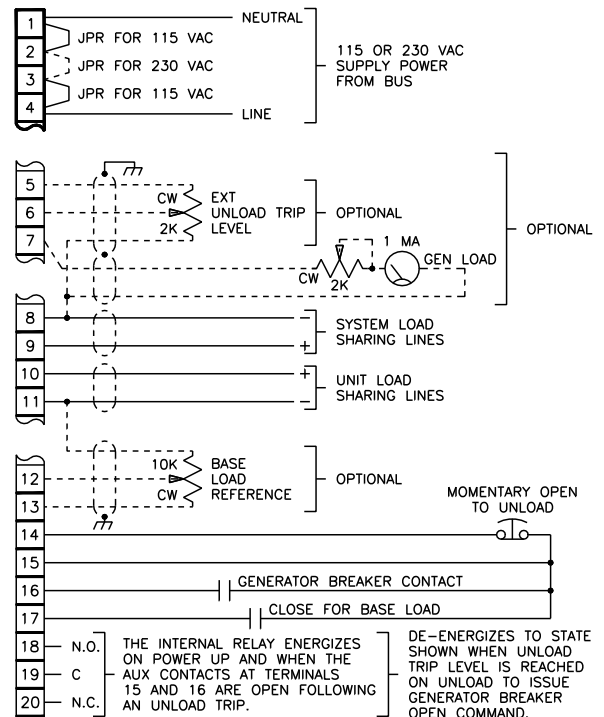

3800 N. Wilson Ave.
 P.O. Box 3800
 Loveland, CO, U.S.A.
 80539-3800
 Ph: 1 970-663-3900
 Ph: 1 800-835-5182
 Fax: 1 970-962-7050

www.woodward.com



International Plants
 Australia, New South Wales
 Brazil, Campinas
 China, Tianjin
 Germany, Aken/Elbe & Kelbra
 India, Haryana
 Japan, Tomisato & Kobe
 Netherlands, Hoofddorp & Rotterdam
 Singapore
 United Kingdom, Reading, England, & Prestwick, Scotland
 United States, Colorado[2], Illinois[3], Michigan[2], New York, South Carolina, Tennessee

Regional Sales Offices
 Canada, Québec
 China, Beijing
 Czech Republic, Plzen
 Germany, Tettngang
 Korea, Pusan
 Mexico, Mexico City
 New Zealand, Christchurch
 Poland, Warsaw
 United Arab Emirates, Abu Dhabi
 United States, Alabama, California, Illinois, Pennsylvania, Texas, Washington

Distributors & Service
 Woodward has a network of distributors and service facilities. For your nearest representative call 1 800-835-5182 or see the Worldwide Directory on our web site.

CORPORATE HEADQUARTERS/
 AIRCRAFT CONTROLS
 Rockford, IL, U.S.A.
 1 815-877-7441

This document is distributed for informational purposes only. It is not to be construed as creating or becoming part of any Woodward Governor Company contractual or warranty obligation unless expressly stated in a written sales contract.

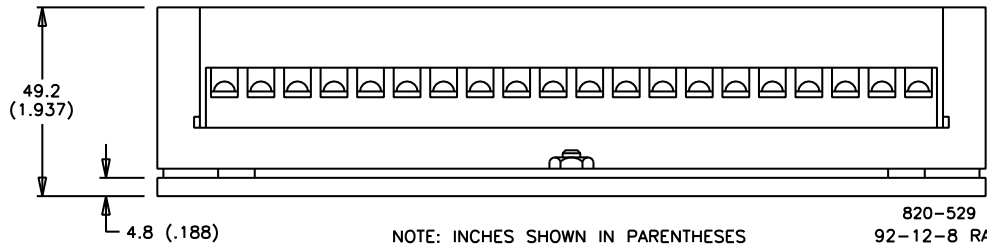
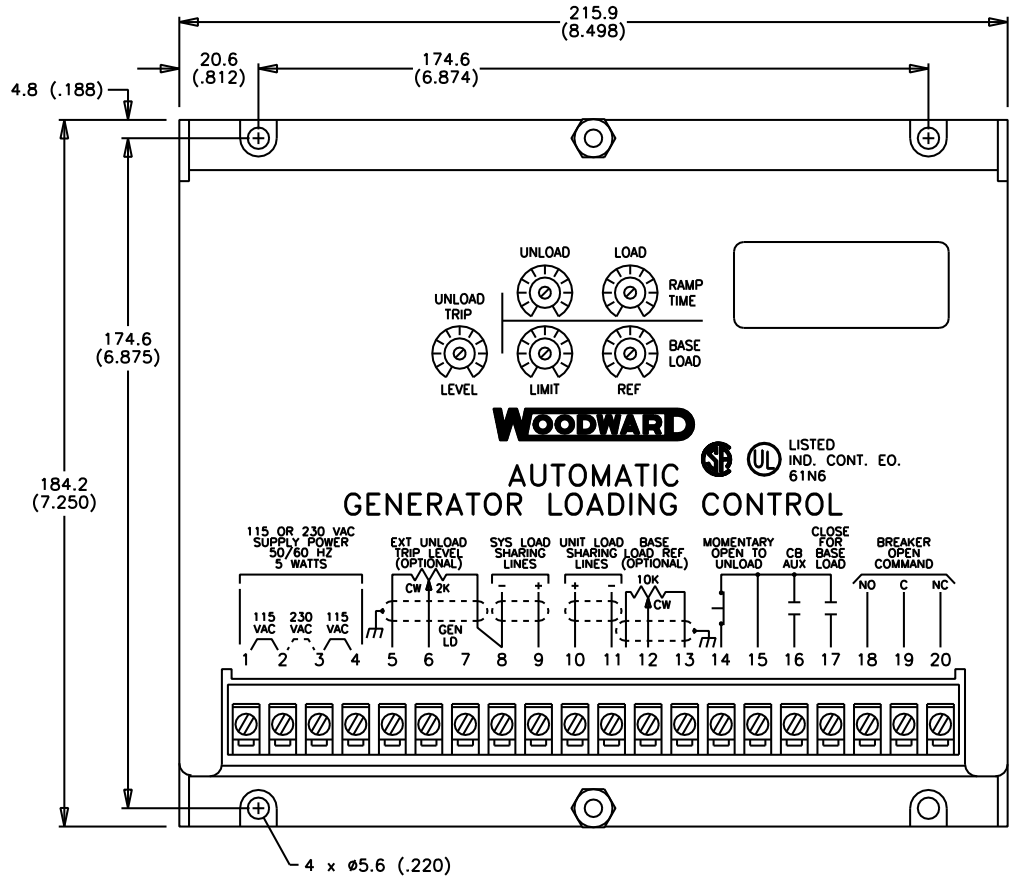

AGLC OUTLINE DRAWING

For more information contact: